

GSOV25

Gas Shutoff Valve

Applications

The Woodward GSOV25 gas shutoff valve is designed to provide extremely fast shutoff of any gaseous flow for industrial gas turbines. Gas flow is stopped when the valve is closed, with zero leakage from inlet to outlet.

The normally-closed valve may be used for emergency and normal shutdown operation. The special seal design in the main piston valve allows long life and prevents leakage. Stainless steel construction assures availability of the valve in spite of corrosive service conditions.

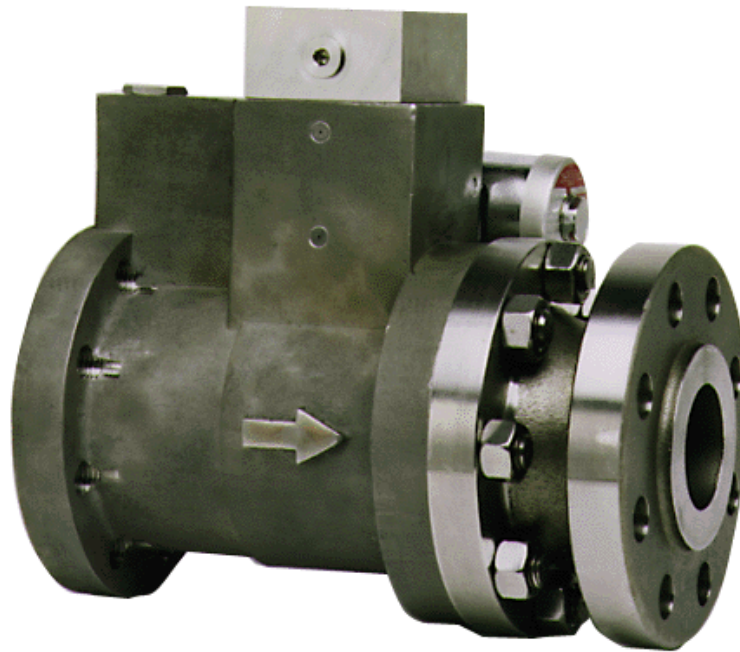

Description

The GSOV25 gas shutoff valve provides shutdown on a gas turbine by rapidly halting the flow of gaseous fuel. The supply pressure is used to move a spring-loaded piston in the valve. When the valve is energized, gas pressure drives the spring-loaded piston open, admitting fuel to the turbine. When the current signal to the electrical solenoid is interrupted, the spring loaded second-stage piston changes states to vent off primary control pressure. The main spring then forces the primary piston to the seal, stopping flow.

- Rated at <10 psi (69 kPa) pressure drop at flow of 25 000 lb/h (11 340 kg/h)
- Closes in <0.100 seconds at 900 psig (6200 kPa)
- Better than Class VI shutoff
- 150 to 900 psig (1034 to 6200 kPa) operating pressure
- Designed for natural gas, propane, ethane, or methane
- Operates from line pressure with no external connections required or with external pilot pressure
- Models are available with certification for North American Hazardous Locations
- Models are available compliant with applicable CE Directives—ATEX, Pressure Equipment, and Machinery

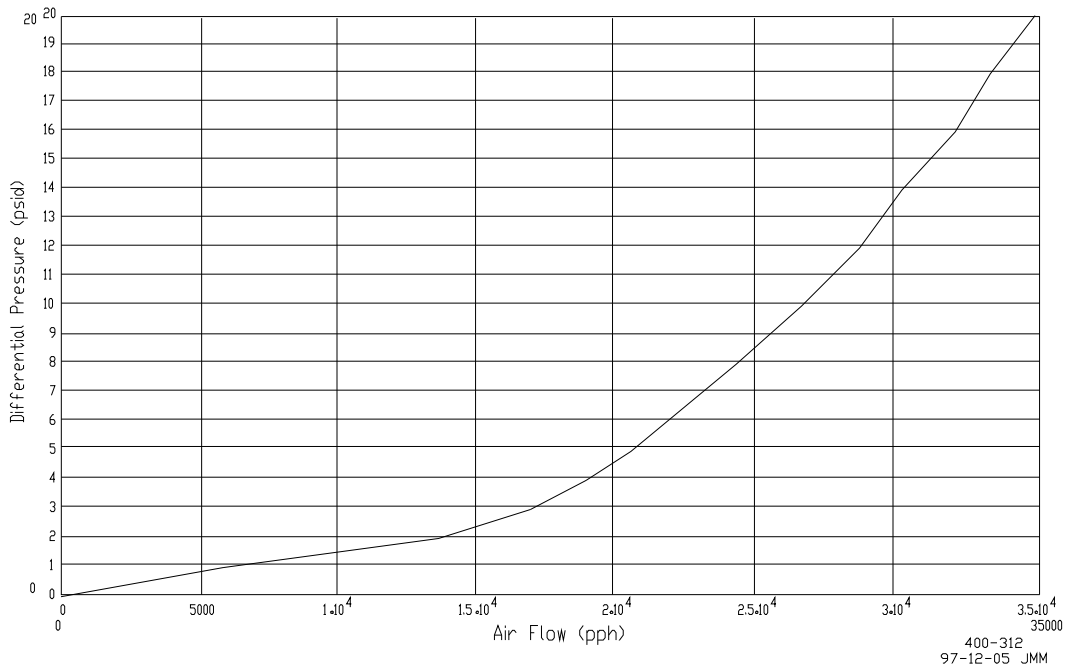

GSOV25 Pressure Drop vs Flow
(Based on air flow at 600 psia 502° R)

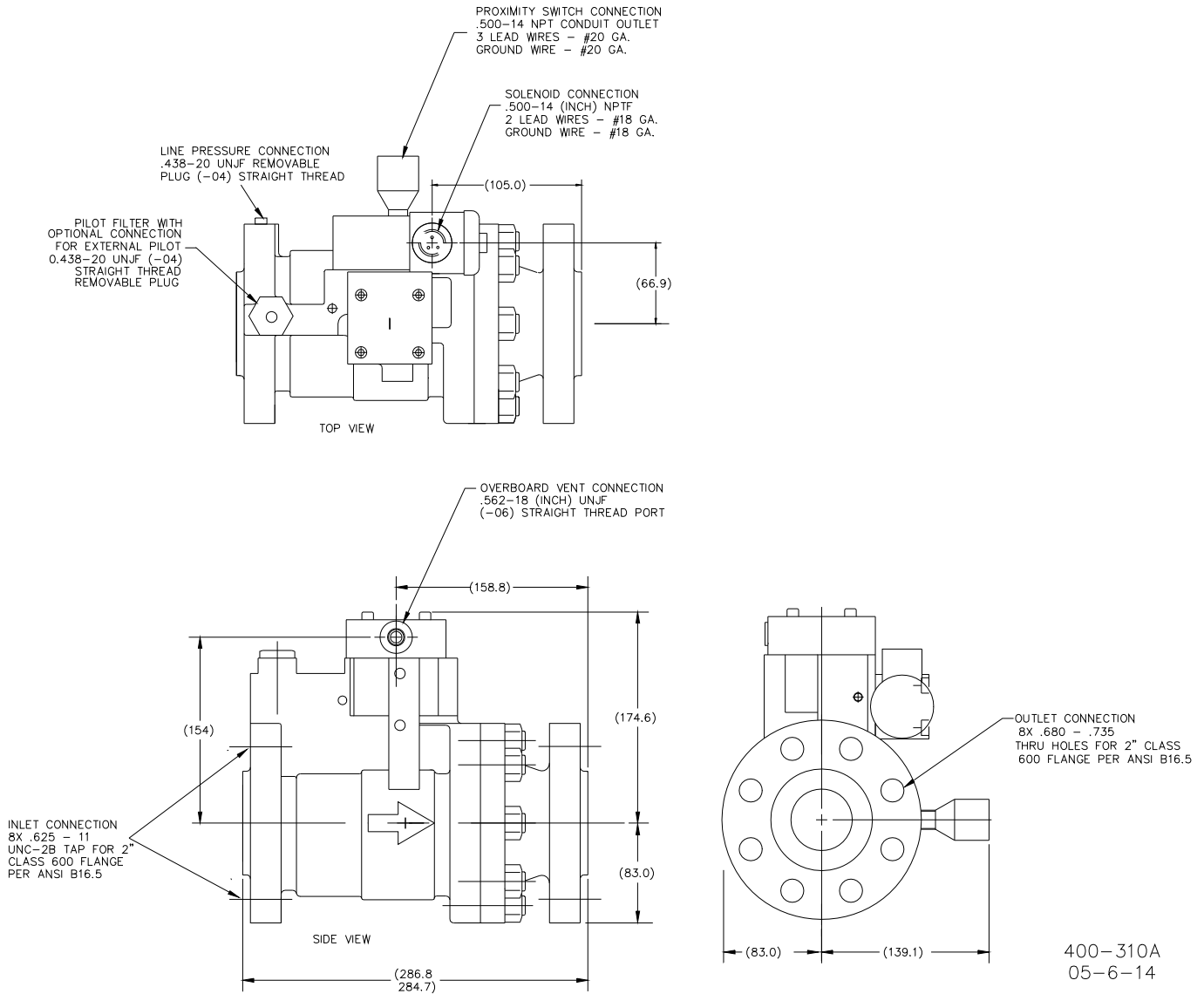

Gas Shutoff Valve
(Do not use for construction)

Specifications

Performance

Closing Time	Within 0.100 second at 900 psi (6200 kPa) supply pressure Within 0.085 second at 600 psi (4137 kPa) supply pressure
Opening Time	0.300 second maximum at 150 psi (1034 kPa) minimum supply pressure
Pressure Drop	<10 psi (69 kPa) at 25 000 lb/h (11 340 kg/h) (see graph)
Seat Leakage Class	ANSI/FCI 70-2, Class VI
Rated Flow	25 000 lb/h (11 340 kg/h)
Cycle Life	20 000 cycles
Pilot Valve Vent	Shall not exceed 1000 SCCM
Reverse Pressure Condition	0 from valve inlet with 200 psig (1379 kPa) applied to the valve outlet with valve inlet at atmospheric pressure and solenoid de-energized

Operating Conditions/Environment

Chemical Compatibility	NACE Compliant for all typical gas fuels; call Woodward for special applications
Fuel Temperature	-4 to +302 °F (-20 to +150 °C)
Ambient Temperature	-4 to +302 °F (-20 to +150 °C)
Fuel Types	Natural gas, propane, ethane, methane
Fuel Supply Pressure	Normal operation 150 to 900 psig (1034 to 6200 kPa)
Proof Pressure	1350 psig (9308 kPa)
Burst Pressure	5000 psig (34 475 kPa)
Fuel Solid Particle Contaminant	Less than 10 µm diameter, 30 lb/min (14 kg/min) by volume maximum Greater than 10 µm diameter, 0.3 lb/min (0.14 kg/min) by volume maximum
Pilot Filtration	40 µm
External Pilot Pressure (optional)	200 to 900 psig (1380 to 6200 kPa)

Electrical Specifications

Voltages Available	Nominal 24 Vdc, 125 Vdc
Power Consumption	10 W maximum
Resistance to Ground	50 MΩ minimum at 500 Vdc
Wiring Interface	Electrical 1/2-14 NPT for electrical conduit; interface 36-inch (914 mm) leads on solenoid, 18 inch (457 mm) on proximity switch
Proximity Switch	SPDT, Normally open and closed contacts to indicate valve closure

Mechanical Specifications

Installation	Flange per ANSI B16.5; 600 lb (272 kg) rating dimension, 2 inch (51 mm) nominal pipe size (6.500 dia. flange with eight 0.625-11 UNC taps through on 5.000 bolt circle on inlet end; 6.500 diameter flange with eight 0.688 holes through on a 5.000 bolt circle on outlet end)
Seal Overboard/Vent Connection	0.562-18 UNJF (-06) straight thread
Weight	72 pounds (33 kg)
Line Pressure Tap (removable plug)	0.438-20 UNJF (-04) straight thread
External Pilot Connection	0.438-20 UNJF (-04) straight thread
Construction	Stainless steel housing; precipitation-hardened stainless steel internal components
Technical Manual	40172

Regulatory Compliance

European Compliance for CE Marking:

These listings are limited only to those units bearing the CE Marking.

Pressure Equipment Directive:

Certified to Pressure Equipment Directive 97/23/EC of 29 May 1997 on the approximation of the laws of the Member States concerning pressure equipment, Category II.

ATEX–Potentially Explosive Atmospheres Directive:

Declared to 94/9/EC COUNCIL DIRECTIVE of 23 March 1994 on the approximation of the laws of the Member States concerning equipment and protective systems intended for use in potentially explosive atmospheres. LCIE 02.ATEX.6145X
Zone 1, Category 2, Group II G, Ex d IIB T3

Other European Compliance:

Compliance with the following European Directives or standards does not qualify this product for application of the CE Marking.

Machinery Directive:

Compliant as a *safety component* with 98/37/EC COUNCIL DIRECTIVE of 23 July 1998 on the approximation of the laws of the Member States relating to machinery.

North American Compliance:

These listings are limited only to those units bearing the CSA agency identification.

CSA:

CSA Certified for Class I, Division 1, Groups C & D, T3C at 150 °C ambient. For use in Canada and the United States.

SIL: Safety Integrity Level:
 Systematic Capability: SC 2 (SIL 2 Capable)
 IEC 61508 Failure Rates in FIT*

Application	λ_{SD}	λ_{Su}^2	λ_{DD}	λ_{DU}
Full Stroke, Clean Service	0	779	0	842
Tight Shut-off, Clean Service	0	779	0	1366

FIT = 1 failure / 10⁹ hours

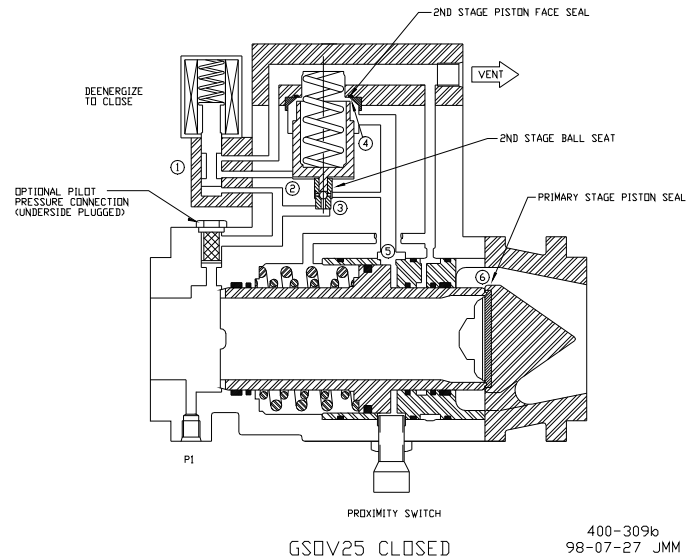
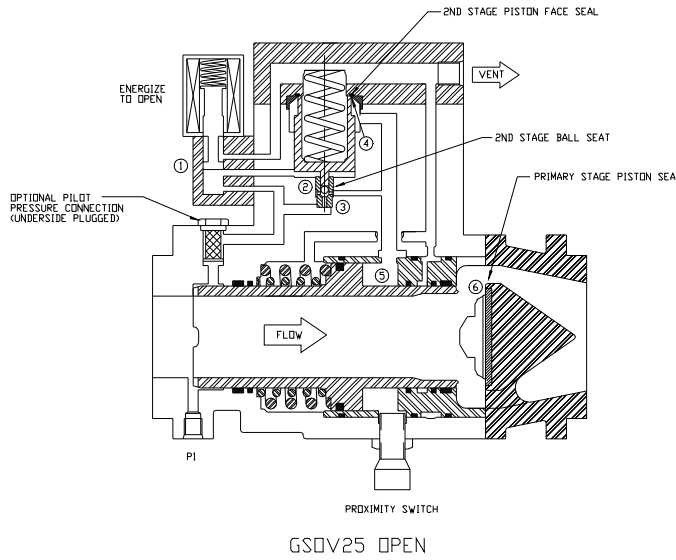

400-309b
98-07-27 JMM

To Open the GSOV25:

- Energize the solenoid with appropriate voltage (24 Vdc or 125 Vdc) (1).
- The three-way solenoid connects P1 or externally supplied pilot pressure to the lower side of the 2nd stage piston (2).
- At pressures greater than 150 psig (1034 kPa), the 2nd stage piston is driven to the top of its bore and seals against the 2nd stage face seal (4). Simultaneously, P1 or pilot pressure is allowed to flow past the 2nd stage ball seat (3) and into the primary piston cavity.
- The P1 or pilot pressure acting on the primary stage piston (5) overcomes the spring force of the return springs and drives the piston to the end of its bore, separating the piston from the primary seal (6).
- Proximity switch indicates valve is open.

To Close the GSOV25:

- De-energize the solenoid (1).
- The three-way solenoid connects the pressure on the lower side of the 2nd stage piston to the atmospheric vent.
- The 2nd stage return spring drives the 2nd stage piston to the bottom of its bore (2). This isolates P1 or pilot pressure from the primary piston cavity by seating the 2nd stage ball against its seat (3). Simultaneously, the 2nd stage piston separates from its face seal (4) and allows the primary piston cavity (5) to vent to atmosphere.
- The primary stage return spring drives the primary stage piston against the primary stage seal (6).
- Proximity switch indicates valve closure.



PO Box 1519, Fort Collins CO, USA 80522-1519
 1000 East Drake Road, Fort Collins CO 80525
 Tel.: +1 (970) 482-5811 • Fax: +1 (970) 498-3058
www.woodward.com

Distributors & Service

Woodward has an international network of distributors and service facilities. For your nearest representative, call the Fort Collins plant or see the Worldwide Directory on our website.

This document is distributed for informational purposes only. It is not to be construed as creating or becoming part of any Woodward contractual or warranty obligation unless expressly stated in a written sales contract.

Copyright © Woodward 1998–2009, All Rights Reserved

For more information contact:

